

3D CAMERA RECOGNITION

The unique 3D camera recognizes the package geometry during production, automatically saves the data in the package program and automatically determines the perfect labeling position.

Especially with irregular products, such as whole chicken, vegetables in tubular bag packaging, skin packaging or cheese, this solution is optimally used.



Different product geometries, e.g. flow wrapped packages



Irregular product geometries, e.g. natural products



Irregular product size and positioning in skin- and stretch packages



Labelling of rising / falling edges

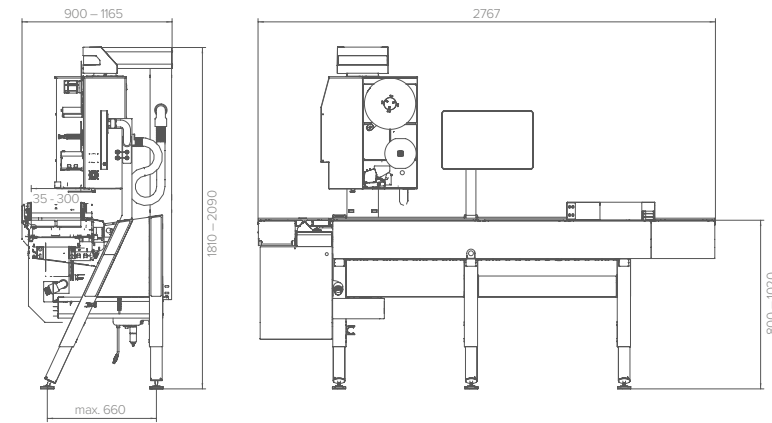

Terminal	21" Swipe-Display
Operator interface	ESPERA Think4Industry
Weight range for weigh price labelling mode (in g)	20 – 10.000
Weight range for checkweigher mode (in g)	50 – 10.000
Scale related mode	10 kg (M); 3/6/10 kg, 1/2/5 g
Power	Up to 140 P/min.
Supply mode	Automatic
Product orientation	Product guides (can be removed completely)
Package sizes in dynamic mode (in mm, L x W x H)	400 x 380 x 160 *
Package sizes in start/stop mode (in mm, L x W x H)	380 x 470 x 160 *
Conveyor speed	80 m/min.
Product recognition	Lightbarrier, 3D camera
Print resolution	300 dpi
Maximum print speed (in mm/sec.)	300
Print width (in mm)	104
Label size - minimum top printer (in mm, L x W)	32 x 36
Label size - maximum top printer (in mm, L x W)	180 x 110
Label size - minimum bottom printer (in mm, L x W)	36 x 36
Label size - maximum bottom printer (in mm, L x W)	160 x 110
TTF	Optional
Label roll core size (in mm)	76
Label roll outer diameter size (in mm)	300
Label winding	Internal and external
USB	Yes
Ethernet	Yes
Power supply	180 V – 255 V, 50/60 Hz
IP-protection class	IPX5
Total printer	Yes
Multi-printer mode	Yes
Maximum number of printers	4
Remote control	Yes
Network capability	Yes
Storage	SSD
Number of feet	6
Temperature range	-10°C – +40°C
Height compensation / lateral positioning of printer	Automatic / automatic
Height compensation (mm)	160

ONE STEP AHEAD.

ESPERA-WERKE GMBH
Moltkestraße 17 – 33
47058 Duisburg
Germany

Phone: +49 203 30 54 - 0
Fax: +49 203 30 54 - 275
E-Mail: info@espera.com

www.espera.com

* by use of product guides the maximum package width reduces to 295 mm | All values are maximum values

NEW!

Transform Your Weigh Price Labelling Process



INCREASE THE EFFICIENCY – DISCOVER THE NEW WEIGH PRICE LABEL

SmartHead – Full status control of the thermal printhead

Overlook the printing quality and the remaining runtime of the thermal printhead at anytime and adjust the printing quality independently depending on your needs by using the intelligent assist function.

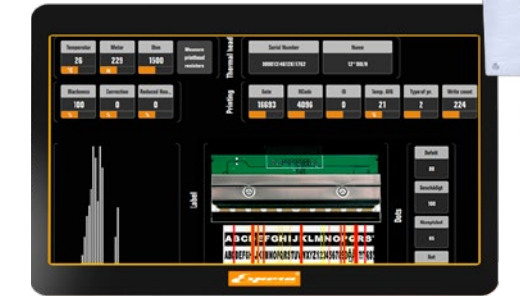

ESPERA NOVA ES-R

The Smart Weigh Price Labelling System - digital, flexible, intuitive.

INCREASE THE EFFICIENCY OF YOUR PRODUCTION – DISCOVER THE NEW GENERATION IN WEIGH PRICE LABELLING **ESPERA NOVA**

SWITCH & GO - MODULAR APPLICATION SYSTEMS

With Switch & Go, you can adapt the **ESPERA NOVA** applicators to suit your products at any time. Choose individually from different applicator variants:



1. Contact-Pendular Applicator

- Path-controlled pendular movement for highest accuracy and highest speed
- Individual label rotation
- Automatic height compensation
- Especially recommended for high speed requirements

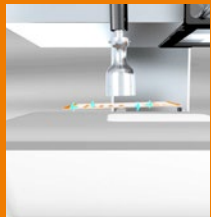

2. Blow-Pendular Applicator

- Path-controlled pendular movement for highest accuracy and highest speed
- Touchless label application via air
- Individual label rotation
- Automatic height compensation
- Especially recommended for high speed requirements



3. Contact-Linear Applicator

- Path-controlled linear movement
- Highest accuracy
- Individual label rotation
- Automatic height compensation
- Especially recommended for medium speed requirements



**INNOVATIVE,
WATER
PROTECTED
AND MUCH
MORE ...**

... further features and innovations please go to **www.esperanext-generation.com**

SMART TECHNOLOGY

We adapt our machines to your production requirements and not vice versa!

Think4Industry

- The smart machine software for an easy and intuitive machine operation

Dynamic Adjust

- Fully automatic adjustment of the printer position and product guides. In combination with the unique 3D camera. The automatic adjustments are defined individually per product on the fly during the labelling process

Fast Change of Label Rolls

- This unique technology reduces downtime and costs for the daily production

Protect+

- Highest water protection thanks to IPX5 protection as well as an allover easy to clean machine design *

Anyview

- Control and operation of the allover labelling process independent from the location, e.g. via smartphone or tablet device.

* Except printer